

# DRINKS | Drink Cabinets

DRINK COOLER ▶ DC LINE ▶ HINGED DOORS ▶ WHITE

# RCG 1350

**CUSTOMIZATION AVAILABLE**  
PERSONALIZZAZIONE DISPONIBILE

+1° | +10°

45 mm | H1 | +1°C | +10°C | ENERGY CLASS C | 3 | +25°C/60RH

LED | Lock | Gasket | Fan | GAS R290



## DETAILS

Bottom hole for easily clean and dry the item

Ventilated unit

Inner vertical LED light

Lock fitted as standard

Main switch, light switch and digital thermostat fitted as standard

## GENERAL FEATURES

- 1000 Lt. Upright drink cooler
- White coated steel for internal and external side
- Ventilated Cooling
- Automatic compressor cycle defrost
- Foaming Agent Cyclopentane (45mm per side)
- Digital Thermostat
- Removable Gasket
- Inner vertical LED light (with independent switch)
- Toughened safety tempered glass with aluminium frame
- Anti-condensation double layer glass
- Self closing door and lock fitted as a standard
- Adjustable shelves: 12 Pcs
- N.4 Wheels for easy positioning
- Energy efficiency class: C

## TECHNICAL SPECIFICATIONS

Capacity	1081 L
Temperature	H1 (+1°C-+10°C)
Consumption	4.638 kWh/24h
Rated Power	460 W
Noise level	58 dB(A)
Net Weight	179 Kg
Gross Weight	197 Kg
External Dimensions (WxDxH mm)	1253x740x2040
Internal Dimensions (WxDxH mm)	1163x543x1495
Packaging dimensions (WxDxH mm)	1278x760x2190
Loading quantities 20'/40'/40'HQ	12/27/27

## PRODUCT DIMENSIONS

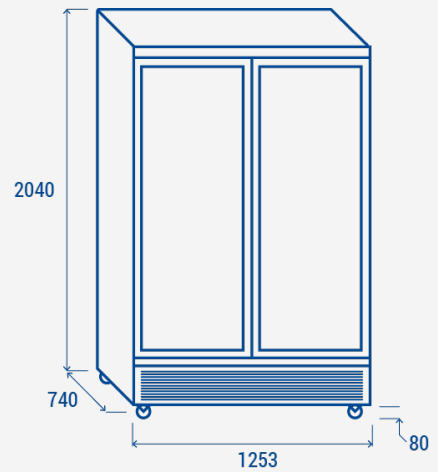

## CERTIFICATION

CE RoHS

